

EVEREST ANALYTICALS

EVEREST GEAR PUMPS, INSTALLATION, OPERATION AND MAINTENANCE INSTRUCTIONS

EVEREST Gear pumps are supplied accurately aligned with the drive at factory before dispatch. The pumps are covered by one-year warranty against manufacturing defects. Some important notes on Installation, Operation and Maintenance are given below:

GUIDANCE FOR INSTALLATION: The pumps should be installed first and the pipe work built away from the pump. This will ensure that there is no strain on the pump, before aligning the Pipeline. The pipeline should be independently supported.

We recommend a cement concrete foundation for the pump. If necessary the whole assembly may be grouted. This is to ensure that there is no vibration of the pump set while running. The alignment of the pump should be rechecked after the complete unit has been installed. A flexible coupling is used to compensate for slight misalignment. There should be a gap of 2mm between coupling halves.

The pump and drive shaft should be aligned as closely as possible. After the alignment is completed, rotate the pump shaft to see that it turns without resistance.

DIRECTION OF ROTATION: In all EVEREST Gear pumps suction and delivery ports can be interchanged i.e. the pumps can work satisfactorily in either direction. If the suction is on the left-hand side, the rotation of the pump should be clockwise looking from the shaft end.

In case the pump is provided with external relief valve arrangement then the direction of the rotation will be as per the arrow indicated.

Ensure that on suction pipe work there is no possibility of leakage, which could result in any, air being drawn into the pump.

Bypass relief valve arrangement: It is recommended that a full flow bypass/relief valve should be installed on the discharge side of the pump to protect the pump and the drive. The liquid by-passed should preferably transferred to the suction tank and not to the inlet of the pump.

FILTER: A full flow filter should be fitted on the suction side of the pump to ensure those foreign materials is not pumped along with the fluid.

Once the installation and alignment is completed ensure that the pump turns freely with slight resistance (due to gland packing).

Contd....2

Suction Side: The suction side forms the most important component of the pumping system. Unless otherwise specified Everest pumps work on flooded conditions & semi vacuum conditions and also depend upon the liquid viscosity, sp gravity, suction piping and valves. In handling viscous fluids, it is advisable to have suction and discharge size larger than pump inlet/outlet size.

START-UP: Before starting the pump it is advisable to release the entrapped air in the piping. For this the plug on the body may be removed and the pump may be rotated manually till all the entrapped air is escaped. It is not advisable to test the pump with water initially for long duration.

All EVEREST Gear pumps are self-priming. However it is advisable to prime the pump initially before start-up. This procedure is unnecessary when the pump has a positive suction.

EVEREST Gear pumps fitted with mechanical seals needs periodic inspection of seal faces. As a part of routine maintenance, seal faces should be kept clean and free of solid particles. Any suitable solvent can clean seal faces. The Gland portion, housing through the seal should be kept cool

EVEREST Gear pumps provided with roller Bearings are pre lubricated before dispatch. The lubrication points are provided on gearbox & end cover. Bearing grease of any good quality is sufficient for this.

STARTUPCHECKLIST: Ensure the pump rotates freely by hand Check that piping is free of foreign materials. See that all piping connections are tight and leak free. Check to see that the pump and drive are well lubricated. Leave packing gland loose for normal seepage. Make adjustments as initial conditions stabilize. See that the Valves are opened on discharge side and all valves are opened on the inlet side.

SERVICE MAINTENANCE: Once the pumps are in running condition EVEREST Gear pumps require very little maintenance. They are:

- 1) Periodical checking of alignment of pump and drive.
- 2) Greasing of bearings regularly.
- 3) Replacement of gland packing whenever necessary.
- 4) In case it is necessary to dismantle or open the pump, it can be easily done by removing the cover without disturbing the Foundation or alignment. Once the cover is removed the gears can be withdrawn easily and the pump can be thoroughly checked for any damage or wear out.

When handling viscous liquids it is quite possible that you may encounter some problems at the time of commissioning. In such a Case you may feel free to approach EVEREST with your specific problems and the matter will be attended at the earliest convenience.

Contact Address:

- 1) Everest Analyticals
103,Godavari Apts,Ghantali,Thane 400602
Tel: 67120726/66733668

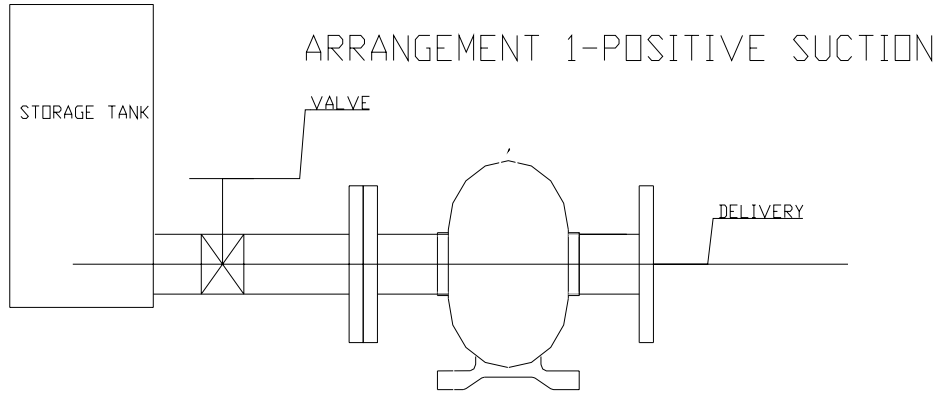

NOTES: KEEP SUCTION LENGTH MINIMUM
SUCTION PIPE SAME AS PUMP SIZE

ARRANGEMENT NO2: NEGATIVE SUCTION

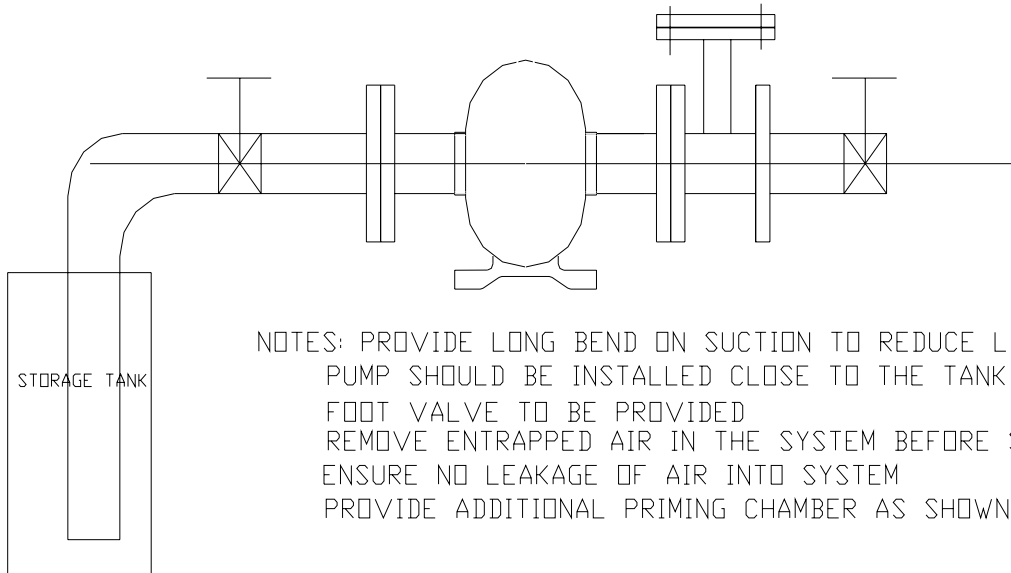

NOTES: PROVIDE LONG BEND ON SUCTION TO REDUCE LOSSES
PUMP SHOULD BE INSTALLED CLOSE TO THE TANK
FOOT VALVE TO BE PROVIDED
REMOVE ENTRAPPED AIR IN THE SYSTEM BEFORE START UP
ENSURE NO LEAKAGE OF AIR INTO SYSTEM
PROVIDE ADDITIONAL PRIMING CHAMBER AS SHOWN IF REQUIRED.